

INSTALLATION STEP 3: FRAME BRACKETS AND CASEMENT BRACKET (SET: SCHÜCO + RAICO)

Frame brackets and Casement bracket (Set: **Schüco + Raico**)

Frame bracket (Set: **Schüco**)

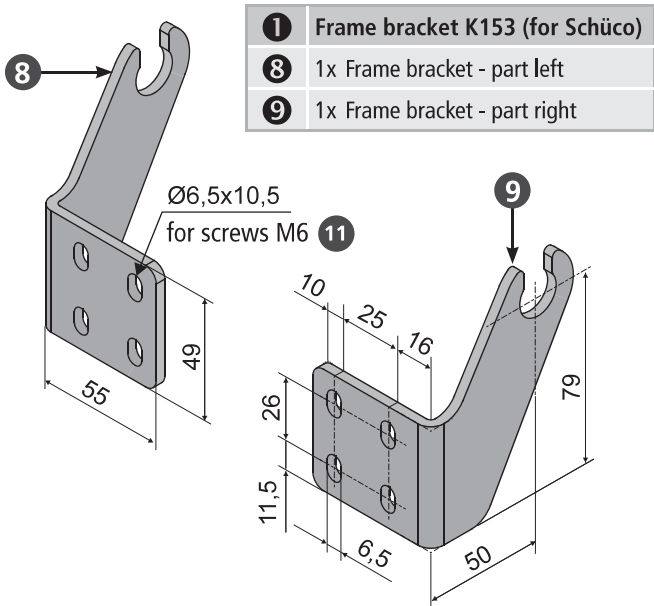

Casement bracket (Set: **Schüco and Raico**)

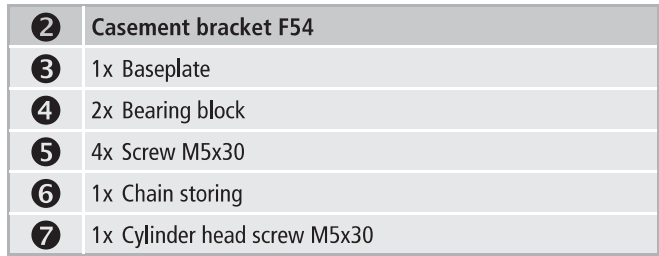

Frame bracket (Set: **Raico**)

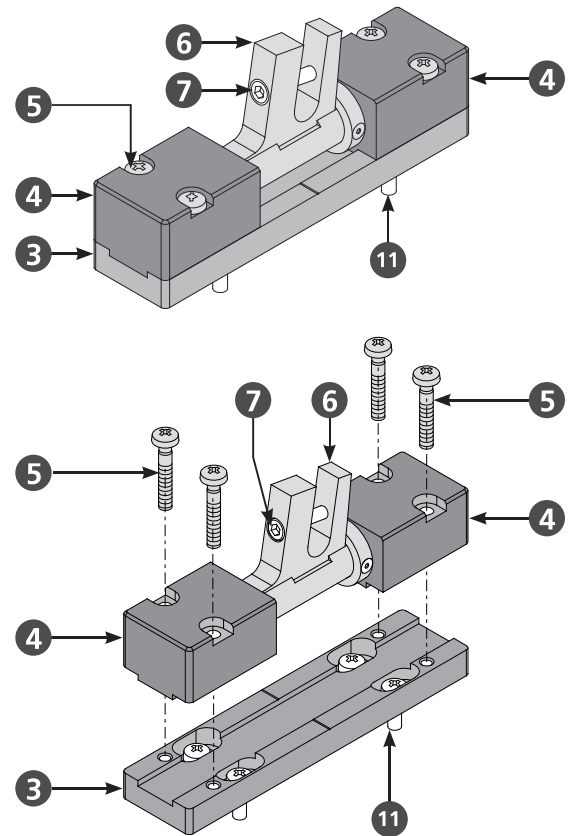
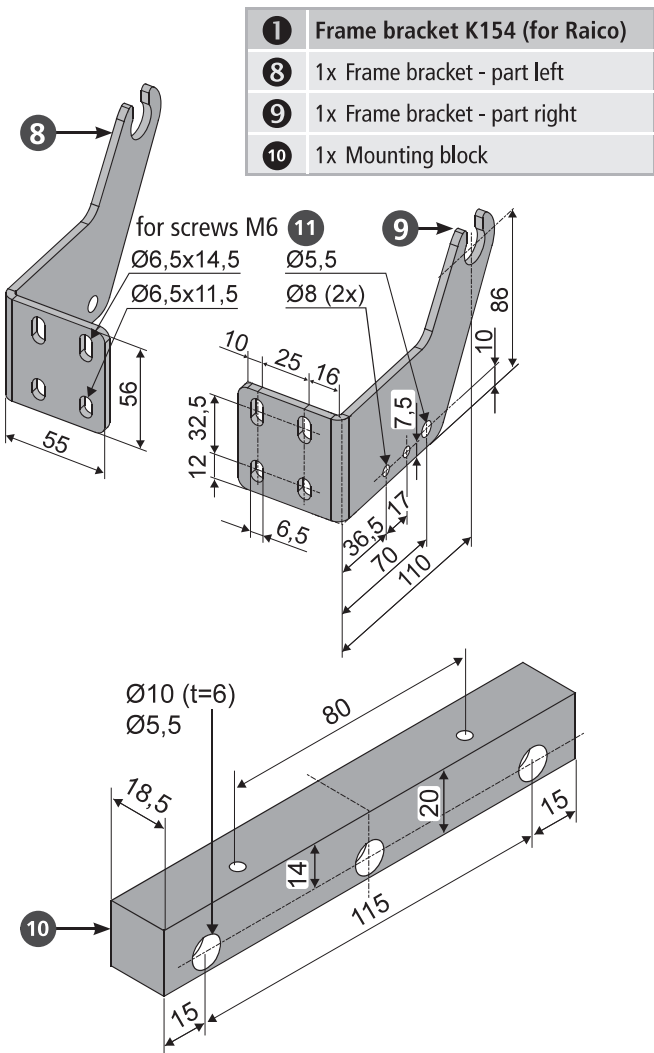

NOTE

Screws **11** - for mounting on the window - are to be provided by the customer!

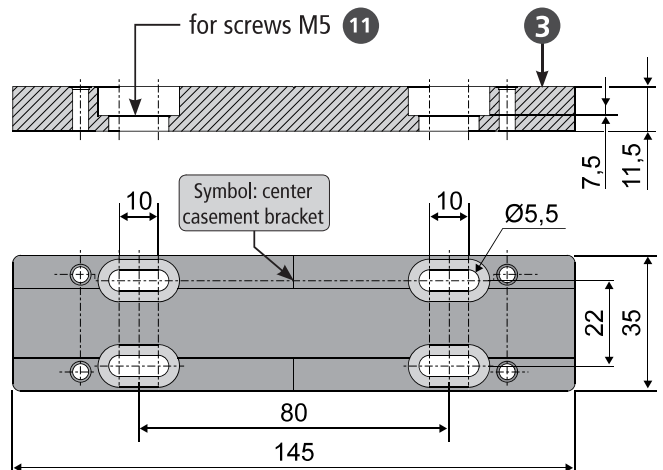

APPLICATION EXAMPLES

Outward opening roof window - frame mounting - Schüco AWS 57RO

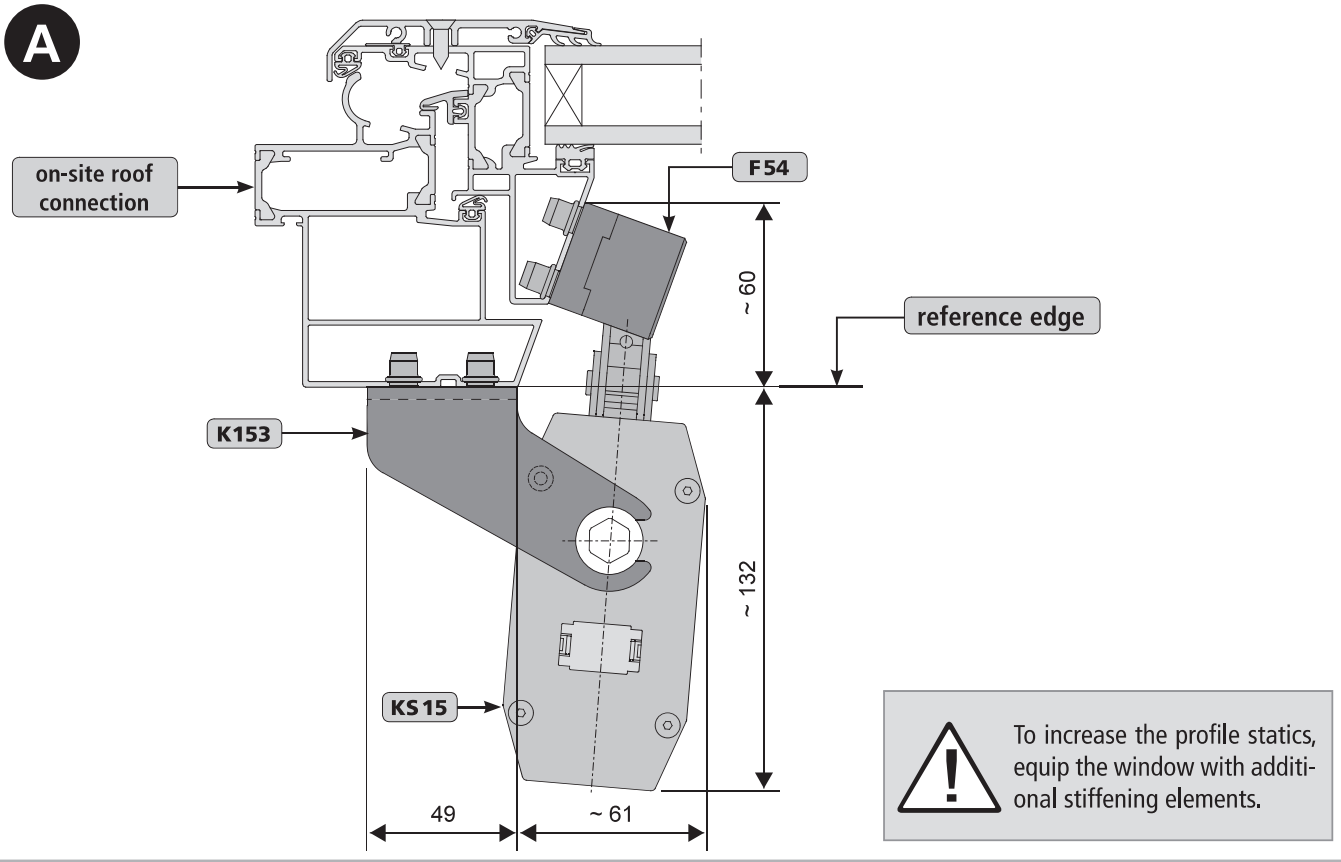

Outward opening roof window - frame mounting - Raico FRAME+100/120RI

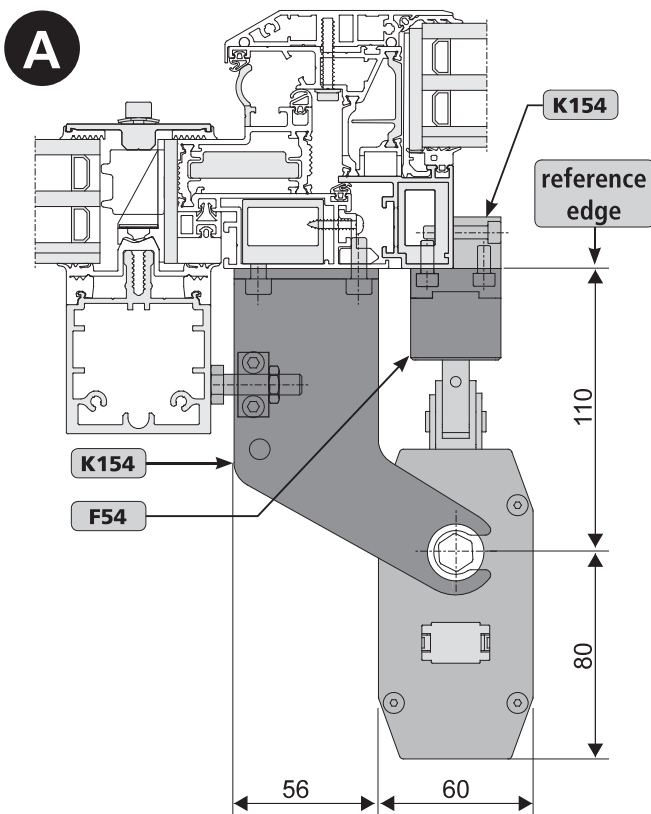

Top-hung outward opening - frame mounting (Mounting universal for facade)

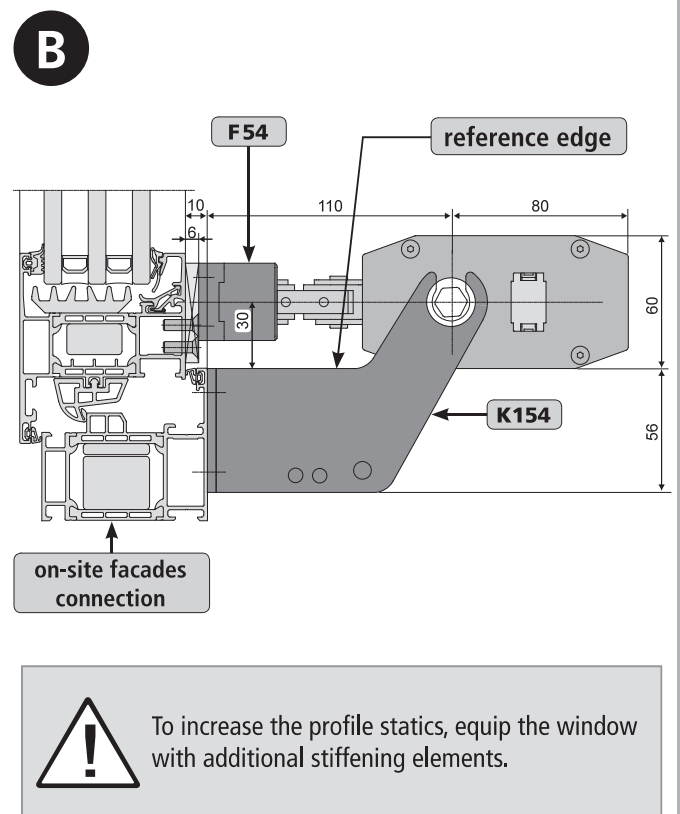

INSTALLATION STEP 4: HOLE LAYOUT FOR FRAME BRACKETS AND CASEMENT BRACKETS

Roof window outward opening - hole layout - frame mounting

A See: **INSTALLATION STEP 5 - 7**



To increase the profile statics, equip the window with additional stiffening elements.

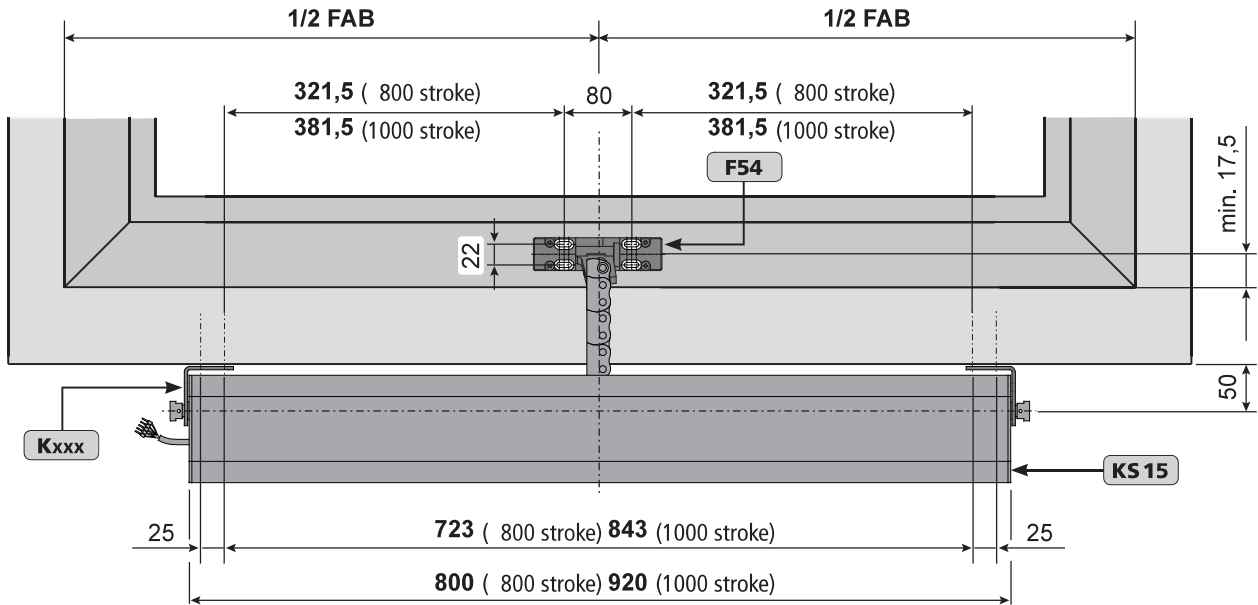
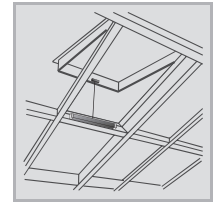

Roof window outward opening - hole layout - frame mounting



To increase the profile statics, equip the window with additional stiffening elements.

